



VMC AND HEAT RECOVERY

VORTICE.COM



# VORT HR W-ALL 100 DF

DUAL-FLOW HEAT RECOVERY UNITS



# VORT HR W-ALL 100 DF

## DUAL-FLOW HEAT RECOVERY UNITS

**VORT HR W-ALL 100 DF** are decentralised dual-flow heat recovery units designed to ensure the correct air exchange of homes as well as residential and commercial premises (firms, offices, hotel rooms, etc.).

The absence of extraction and delivery pipes makes installation quick and economical and helps reduce management costs, by eliminating the need for periodic duct sanitisation.

The high heat exchange efficiency, low consumption, low noise emissions, simple and quick installation make **VORT HR W-ALL 100 DF** the ideal solution to guarantee high levels of environmental comfort in new or renovated premises, characterised by great energy efficiency.



### **BENEFITS FOR THE USER**

**Low noise emissions**, suitable for use in residential rooms (living rooms, firms, bedrooms).

2

**Adaptability** to a wide range of different needs, thanks to the numerous selectable alternative flow rates. The possible extraction of stale air from a room close to the one where the product is installed also makes **VORT HR W-ALL 100 DF** the ideal solution for the ventilation of studios and hotel rooms.

**Significant energy saving**, guaranteed by the low consumption of the fan motors (equal to the consumption of a 3,500 lumen LED lamp, necessary to illuminate a 20 m<sup>2</sup> living room) and the high efficiency of sensible exchange: the figure of 80% implies that, in the presence of outdoor air at 0°C and ambient air at 20°C, the outdoor fresh air enters the room at 16°C, thus drastically limiting the consumption necessary to maintain the indoor temperature.

**High comfort:** The enthalpy exchanger maintains relative humidity rates suitable for the comfort of the occupants even in cold and dry climates, as well as hot and humid.

#### **Great effectiveness:**

- The six alternative flow rates allow to find the best compromise between performance, consumption and noise emissions, as application needs and environmental conditions vary.
- The optimised distribution of the fresh air flow, the result of accurate CFD (Computational Fluid Dynamics) studies, ensures the correct ventilation of the served room (fig. on page 12)

**Simple and intuitive use**, thanks to the integrated humidity sensor, which allows automatic regulation of the treated air flow rate, to control by **VORTICE App (VORTICE HRU)**, and to possible combination to **BRA.VO S** sensors—air quality meters—via WiFi, without costly and impactful masonry works.

### **BENEFITS FOR THE INSTALLER**

#### **Easy installation:**

- The enthalpy exchanger drastically reduces the accumulation of condensation inside the product, allowing its disposal—possible in the presence of particularly high humidity levels—in the flow of the expelled stale air, without the need for ducts.
- The small diameter (100 mm) of the ventilation ducts, which can easily be made with widely used hollow cutters, the reduced dimensions, the limited thickness and the possible wall installation, simplify the installation without the need for complex and expensive masonry works.



## TECHNICAL FEATURES

### 3 MODELS

It is divided into 3 versions, different for the type of installation:

- **VORT HR W-ALL 100 DF W (Cod. 12484)**  
wall-mounted, designed to optimise installation costs and speed up installation.
- **VORT HR W-ALL 100 DF SR (Cod. 12485)** semi-recessed, the ideal compromise between the previous alternatives.
- **VORT HR W-ALL 100 DF R (Cod. 12486)**  
recessed, ideal for minimising the aesthetic impact and encumbrances in the target room.
- **The development of Passive House certified versions has been planned.**
- Designed for easy installation at a perimeter wall.
- They present themselves as a rectangular parallelepiped of limited thickness; the front consists of a white aesthetic panel; on the back there are two spigots, intended for housing in holes of nominal diameter equal to 100 mm, easily made by commonly used hollow cutters, to be drilled in the target wall to suck fresh air and discharge stale air.
- The control panel with LCD display supplied as standard allows the control of the regular operation of the product, the monitoring of filter status, the manual setting, alternative to the automatic one, possible thanks to the relative humidity sensor, and CO<sub>2</sub>, VOC and PM (optional).
- A sensor monitors the concentration of relative humidity in the extracted stale air allowing, in automatic mode, the automatic transition to Boost mode operation when the preset threshold is exceeded.
- The heat exchanger, enthalpic and of the cross-flow type with counterflow, performs the air exchange in the rooms without penalising the comfort of the occupants (the concentration of indoor air humidity never falls below the annoyance threshold) at 50 m<sup>3</sup>/h; the outdoor air at 0°C is introduced into the room at 20°C at the temperature of 17°C.
- A pair of ISO Coarse (G4) and ePM1 60% (F7) filters placed at the intake and delivery ducts protect the internal components from potential damage caused by the accumulation of dirt and dust and ensure good quality of the fresh air.
- Different frames depending on the version, made in zinc-coated white painted steel sheet.
- Aesthetic ABS front panels in semi-recessed and wall-mounted models; in the recessed version, a smooth white PS panel allows customisation by applying aesthetic films or painting, by the customer, in the preferred colour, for better integration into the room.
- Pair of fans, with forward curved centrifugal impellers (to reduce noise emissions), driven by EC (brushless) motors, to guarantee high fresh air flow rates and reduced consumption.

### Regulatory standards

The products of the VORT HRW 100 MONO DF series comply with the following European Norms, Directives and Regulations:

- Electrical Safety Regulations: EN 60335-1; EN 60335-2-80; EN 62233;
- Electromagnetic Compatibility Regulations: EN 55014-1 EN 55014-2 EN 61000-3-2 EN 61000-3-3

- European Directives for CE Marking
- RED Directives (2014/53/EU)
- WEEE Directives (2012/19/EU)

- Low Voltage Directive (2014/35/EU)
- Compatibility Directive (2014/30/EU)
- Ecodesign Directive (2009/125/EC)
- RoHS Directive (2011/65/EU)
- RAEE Directive (2012/19/EU)
- Patent pending

VORTICE is a member of AMCA (Air Movement & Control Association), the association of the world's top manufacturers of aerualic equipment.

**VORT HR W-ALL 100 DF**  
DUAL-FLOW HEAT RECOVERY UNITS

**Dimensions**

**VORT HR W-ALL 100 DF W COD. 12484 WALL-MOUNTED VERSION**

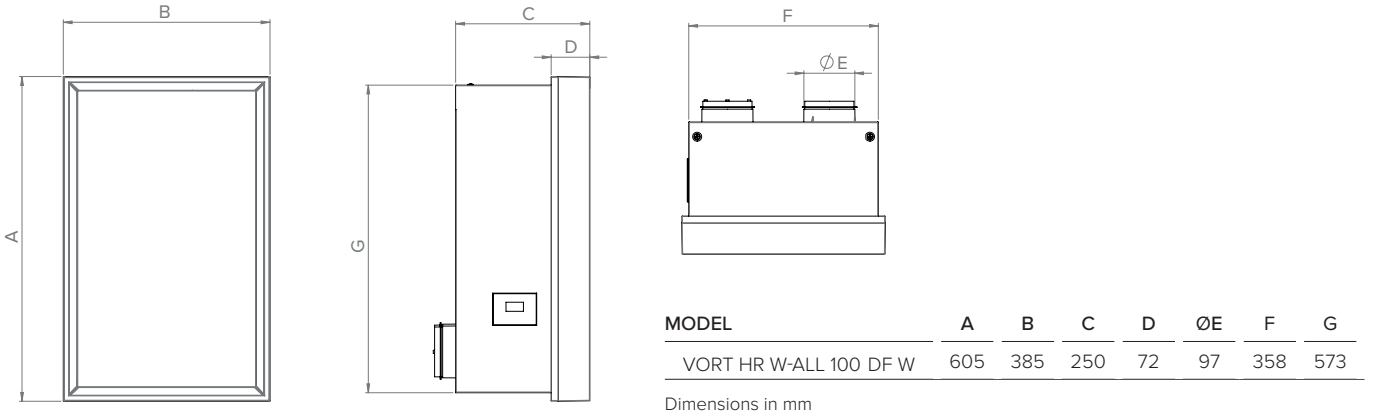

**VORT HR W-ALL 100 DF SR COD. 12485 SEMI-RECESSED VERSION**

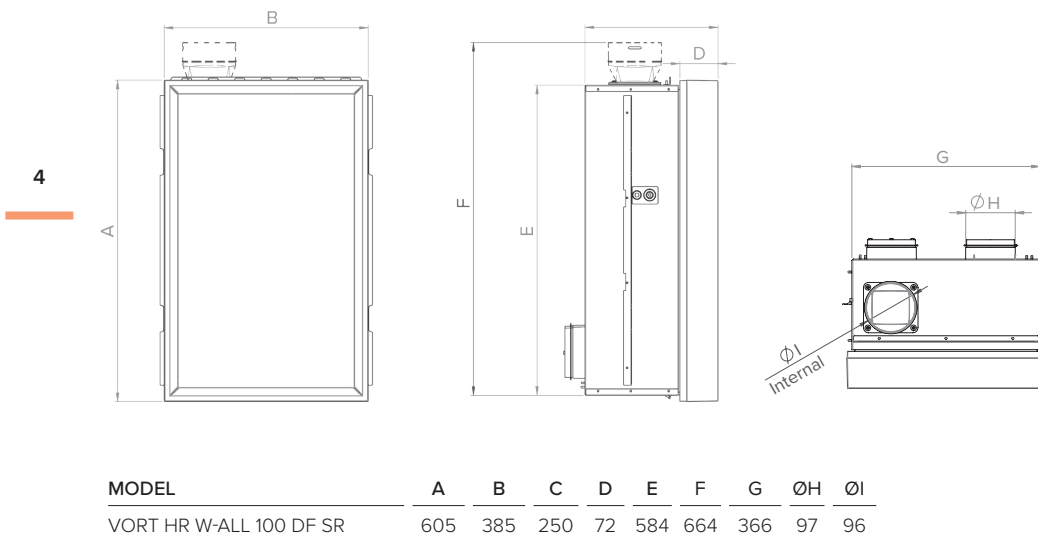

**VORT HR W-ALL 100 DF R COD. 12486 RECESSED VERSION**

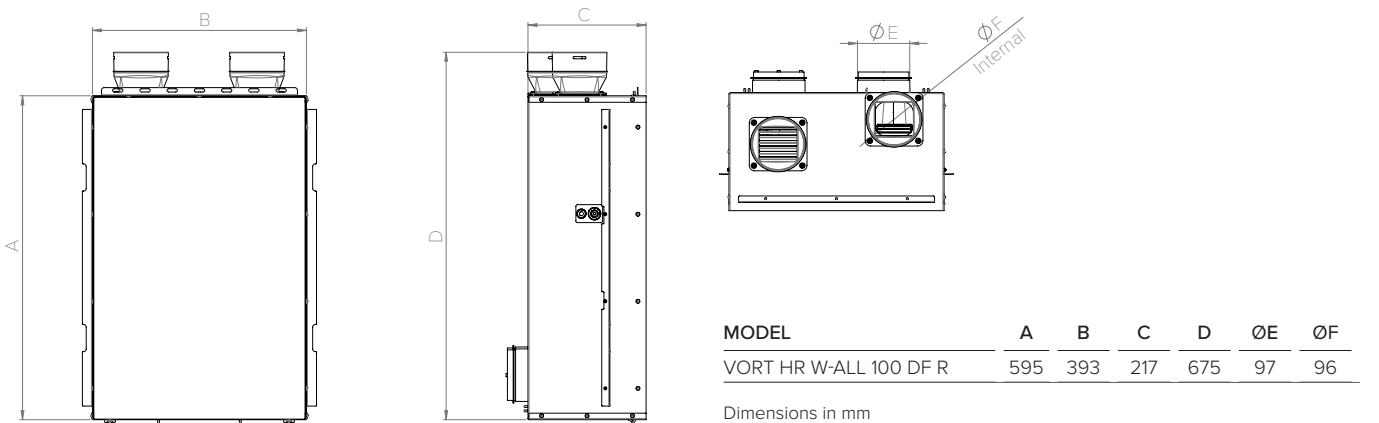

## Technical data

VORT HR W-ALL 100 DF W COD. 12484	V~50-60 HZ	SPEED NUMBER	PHASE NUMBER	IP	MOTOR CLASS	W V1/V2/V3/V4/V5	LP dB (A) max 3 m	°C MIN/MAX	KG
	220-240	5	1	22	B	8/11/16/31/48	39	-5/40	17

VORT HR W-ALL 100 DF W COD. 12484	BOOST	HIGH PERFORMANCE	PERFORMANCE	QUIET	SUPER QUIET
FLOW RATE IN m <sup>3</sup> /h	90	75	50	35	15
Lw dB (A)	57	52	43	36	29
Pa	314	215	105	58	24

VORT HR W-ALL 100 DF SR COD. 12485	V~50-60 HZ	SPEED NUMBER	PHASE NUMBER	IP	MOTOR CLASS	W V1/V2/V3/V4/V5	LP dB (A) max 3 m	°C MIN/MAX	KG
	220-240	5	1	22	B	8/11/16/31/48	39	-5/40	17,6

VORT HR W-ALL 100 DF SR COD. 12485	BOOST	HIGH PERFORMANCE	PERFORMANCE	QUIET	SUPER QUIET
FLOW RATE IN m <sup>3</sup> /h	90	75	50	35	15
Lw dB (A)	57	52	41	32	33
Pa	314	215	105	58	24

5

VORT HR W-ALL 100 DF R COD. 12486	V~50-60 HZ	SPEED NUMBER	PHASE NUMBER	IP	MOTOR CLASS	W V1/V2/V3/V4/V5	LP dB (A) max 3 m	°C MIN/MAX	KG
	220-240	5	1	22	B	8/12/19/39/58	33	-5/40	17,6

VORT HR W-ALL 100 DF R COD. 12486	BOOST	HIGH PERFORMANCE	PERFORMANCE	QUIET	SUPER QUIET
FLOW RATE IN m <sup>3</sup> /h	130	110	70	53	31
Lw dB (A)	50	45	36	31	29
Pa	296	220	104	59	26

\* The company reserves the right to modify the above data without prior notice and whenever necessary.

**VORT HR W-ALL 100 DF**  
DUAL-FLOW HEAT RECOVERY UNITS

**Curves**

**VORT HR W-ALL 100 DF W COD. 12484**  
(WALL INSTALLATION)

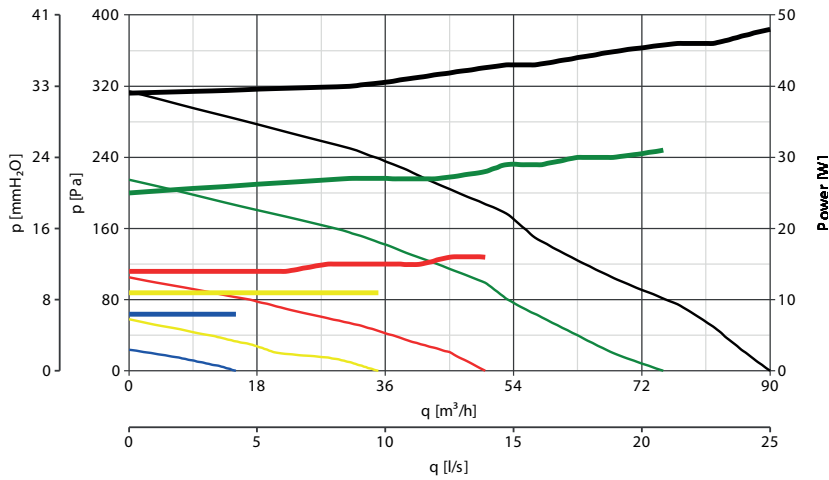

**VORT HR W-ALL 100 DF SR COD. 12485**  
(SEMI-RECESSED INSTALLATION)

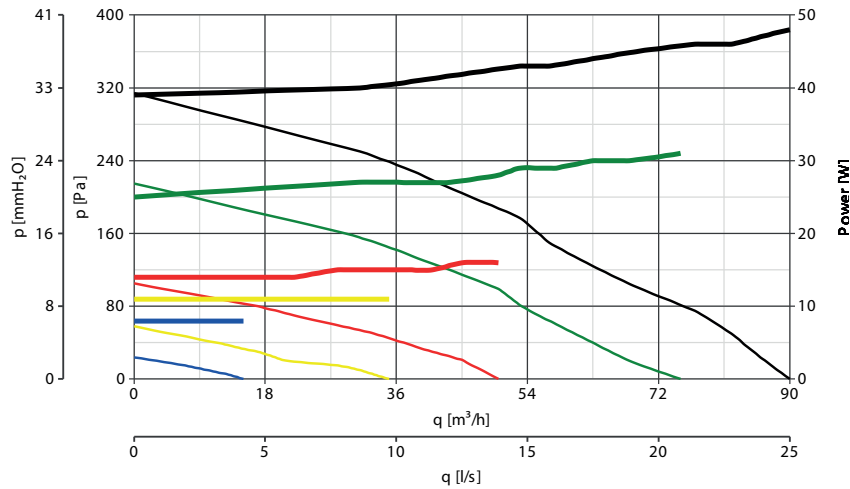

6

In the case of semi-recessed installation (code 12472), the air flow rate extracted from the second room is based on the pressure losses of the relative ducting system. For example, in the case of connection by: WDG75 corrugated pipe, length 3 m (code 21235), plenum (code 26798) plus grid with filter (code 25073) the flow rates at the six alternative settings are:

In the case of a recessed version, the total flow rate extracted and introduced can be inferred from the diagram on the side page.

SET POINT	"Other room" spigot intake flow rate by configuration (code 12472) m <sup>3</sup> /h
SUPER QUIET	8
QUIET	18
PERFORMANCE	25
HIGH PERFORMANCE	41
BOOST	45



Curves

VORT HR W-ALL 100 DF R COD. 12486  
(RECESSED INSTALLATION)

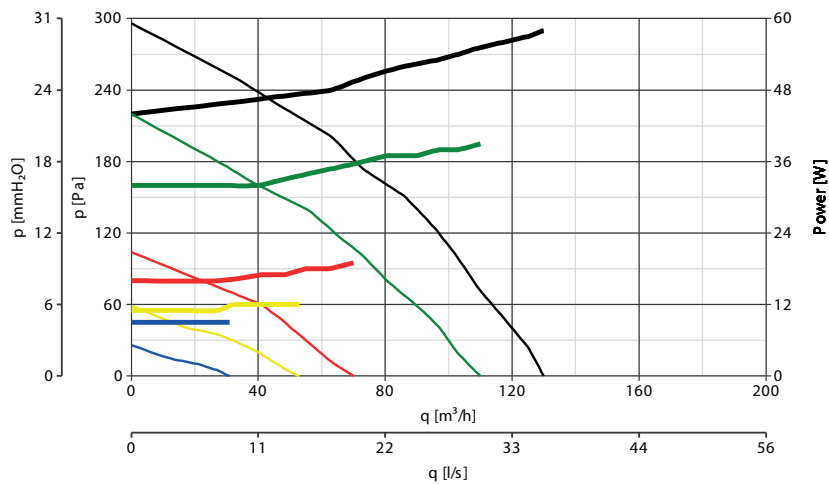

KEY:

BOOST MODE

— Pressure  
— Power

HIGH PERFORMANCE MODE

— Pressure  
— Power

PERFORMANCE MODE

— Pressure  
— Power

QUIET MODE

— Pressure  
— Power

SUPER QUIET MODE

— Pressure  
— Power



## APPLICATIONS

### EXAMPLE OF WALL INSTALLATION VORT HR W-ALL 100 DF W COD.12484

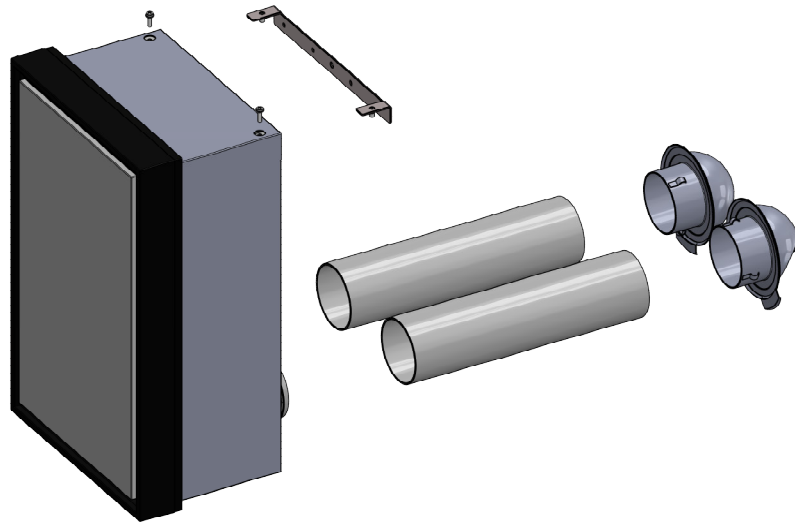

### EXAMPLE OF SEMI-RECESSED INSTALLATION WITHOUT EXTRACTION FROM ANOTHER ROOM VORT HR W-ALL 100 DF SR COD.12485

8

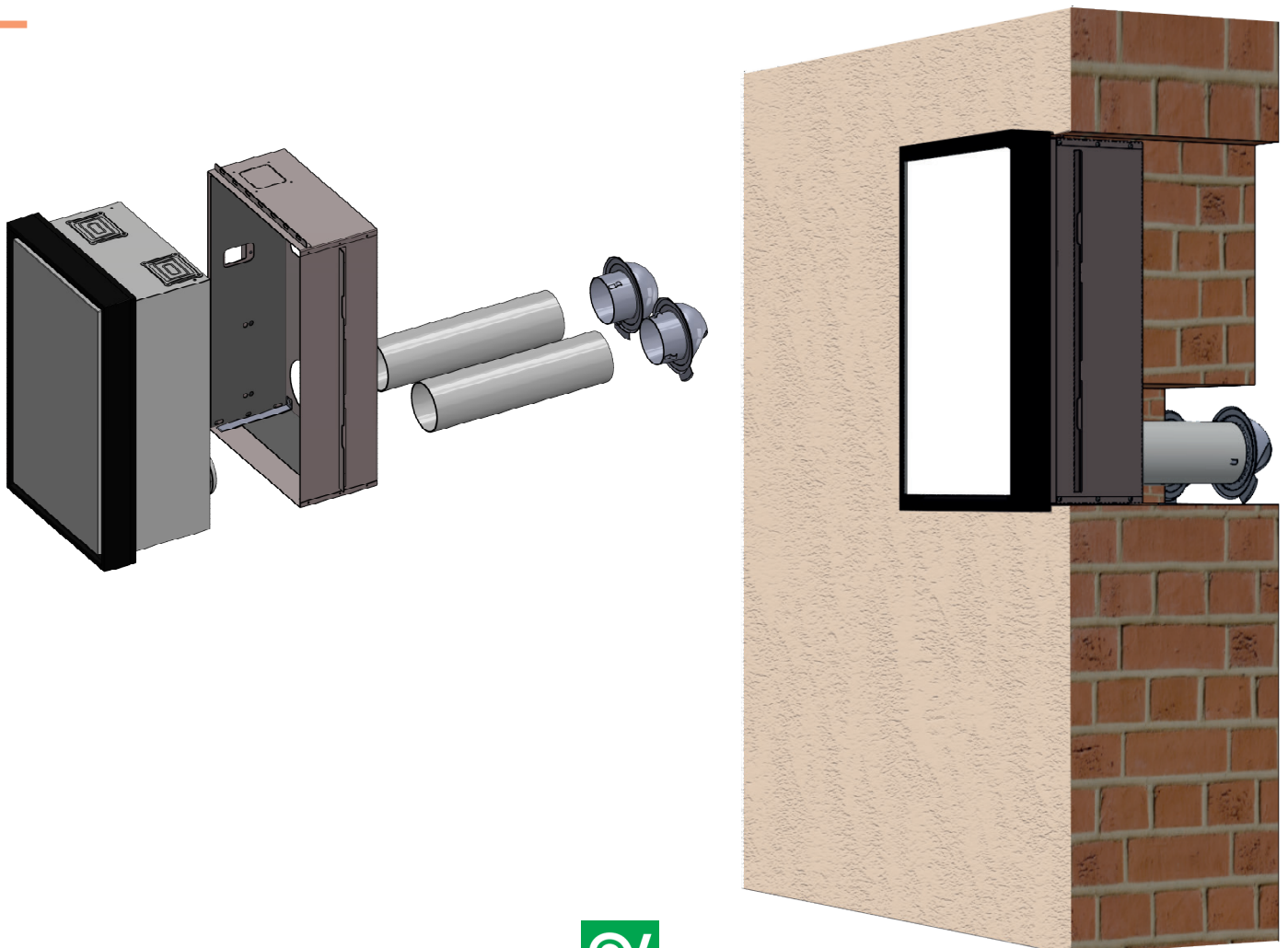



EXAMPLE OF SEMI-RECESSED INSTALLATION WITH EXTRACTION FROM ANOTHER ROOM  
VORT HR W-ALL 100 DF SR COD.12485

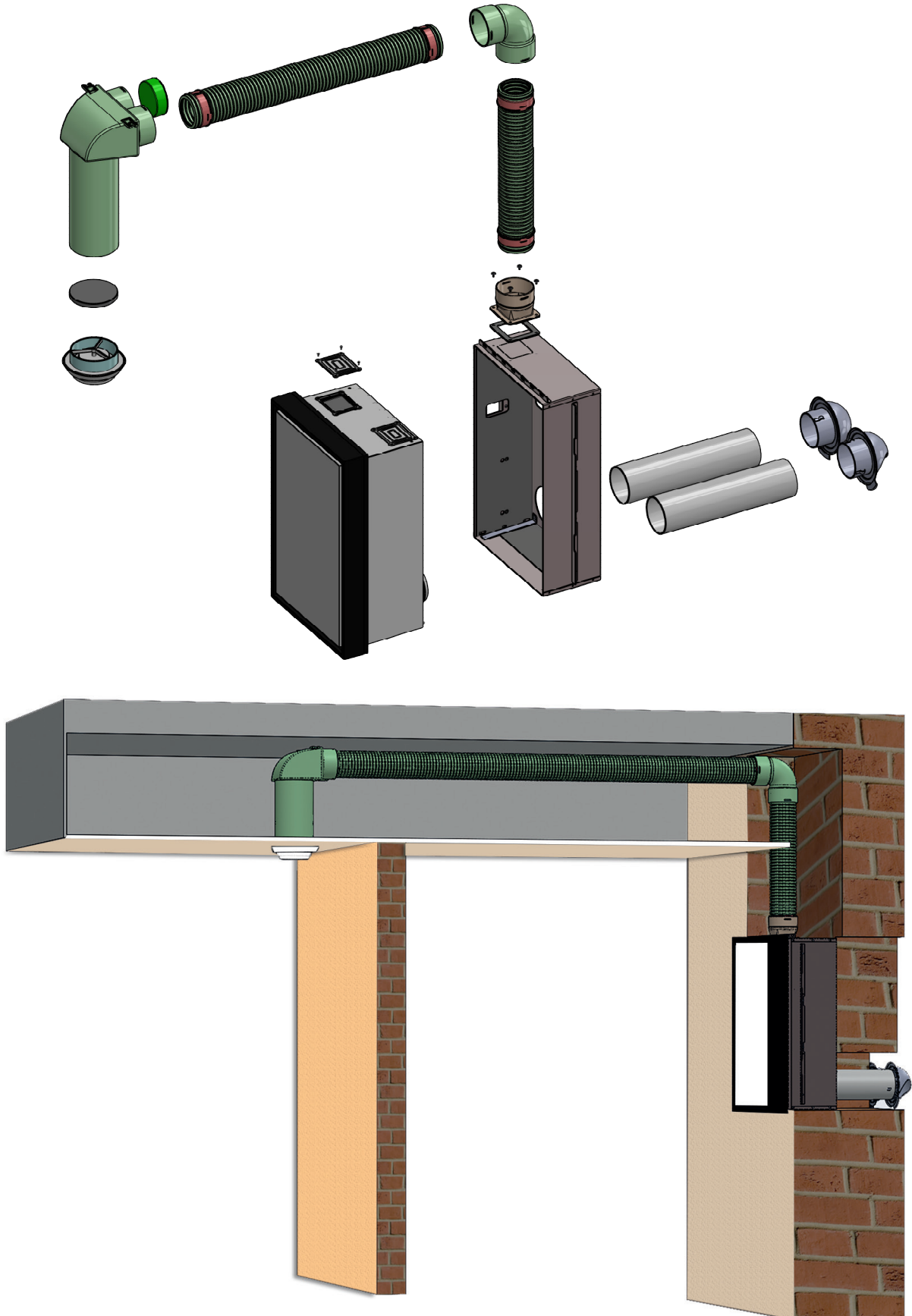

VORT HR W-ALL 100 DF  
DUAL-FLOW HEAT RECOVERY UNITS

EXAMPLE OF RECESSED INSTALLATION FOR VENTILATION OF SEVERAL ROOMS, DUCTS IN FALSE CEILING  
VORT HR W-ALL 100 DF R COD.12486

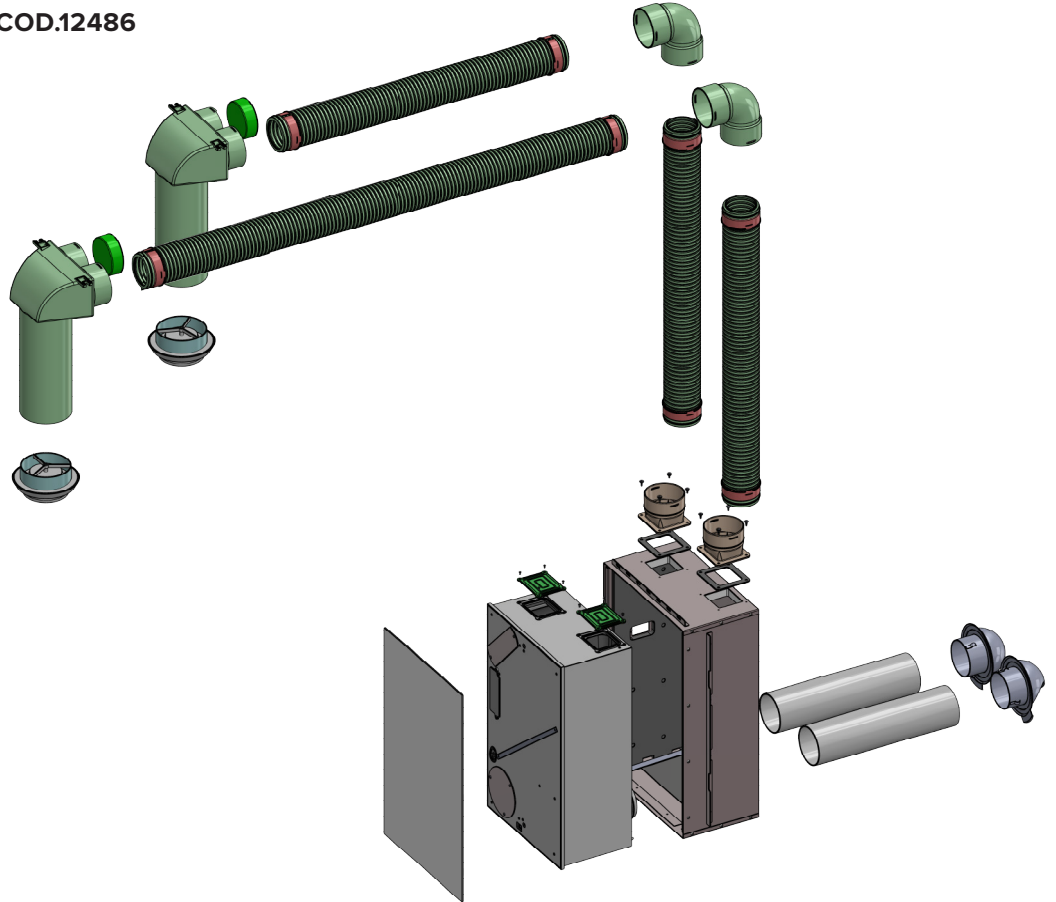

10

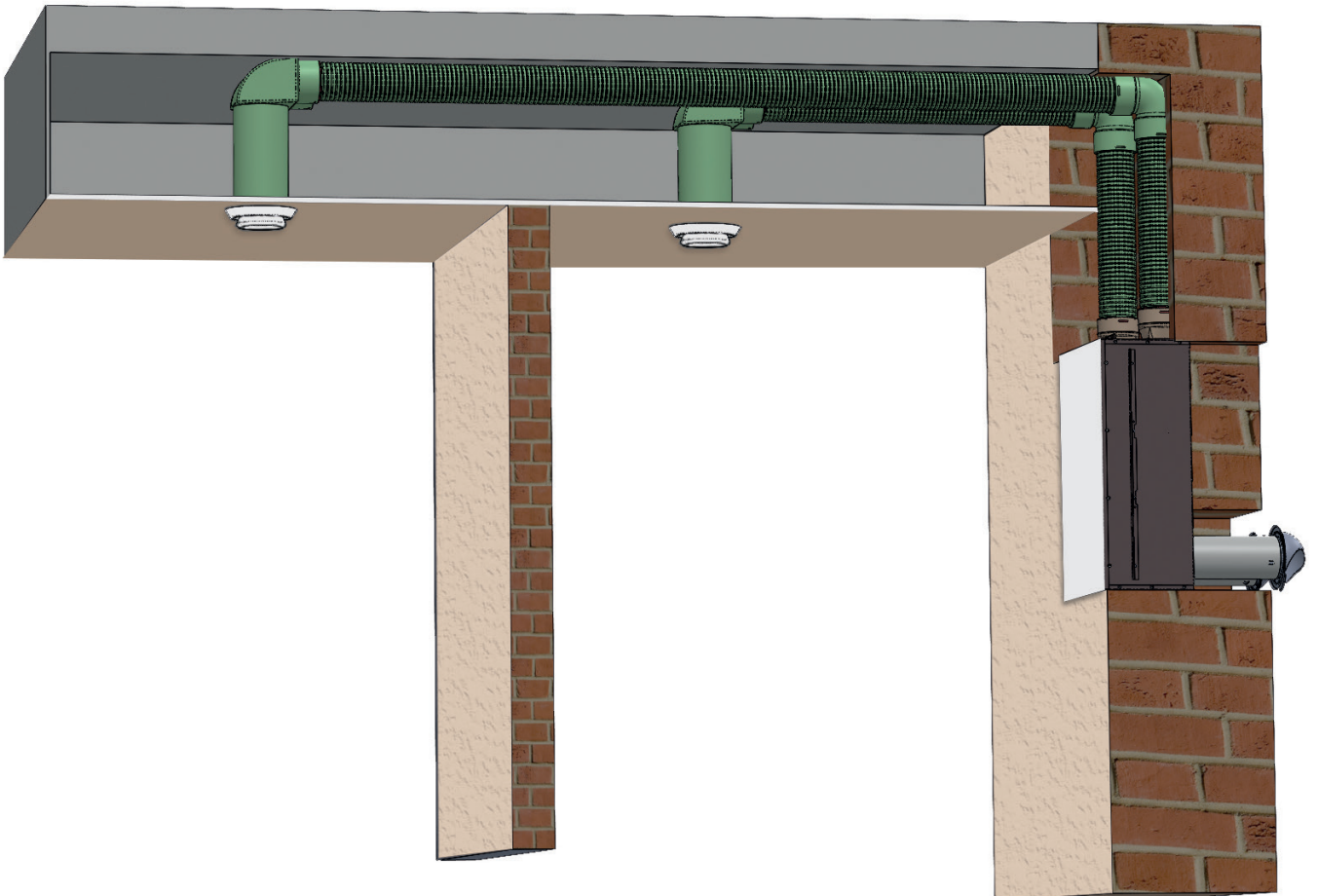

EXAMPLE OF FLUSH-MOUNTED INSTALLATION FOR VENTILATION OF SEVERAL ROOMS, DUCTS IN WALL  
VORT HR W-ALL 100 DF R COD.12486

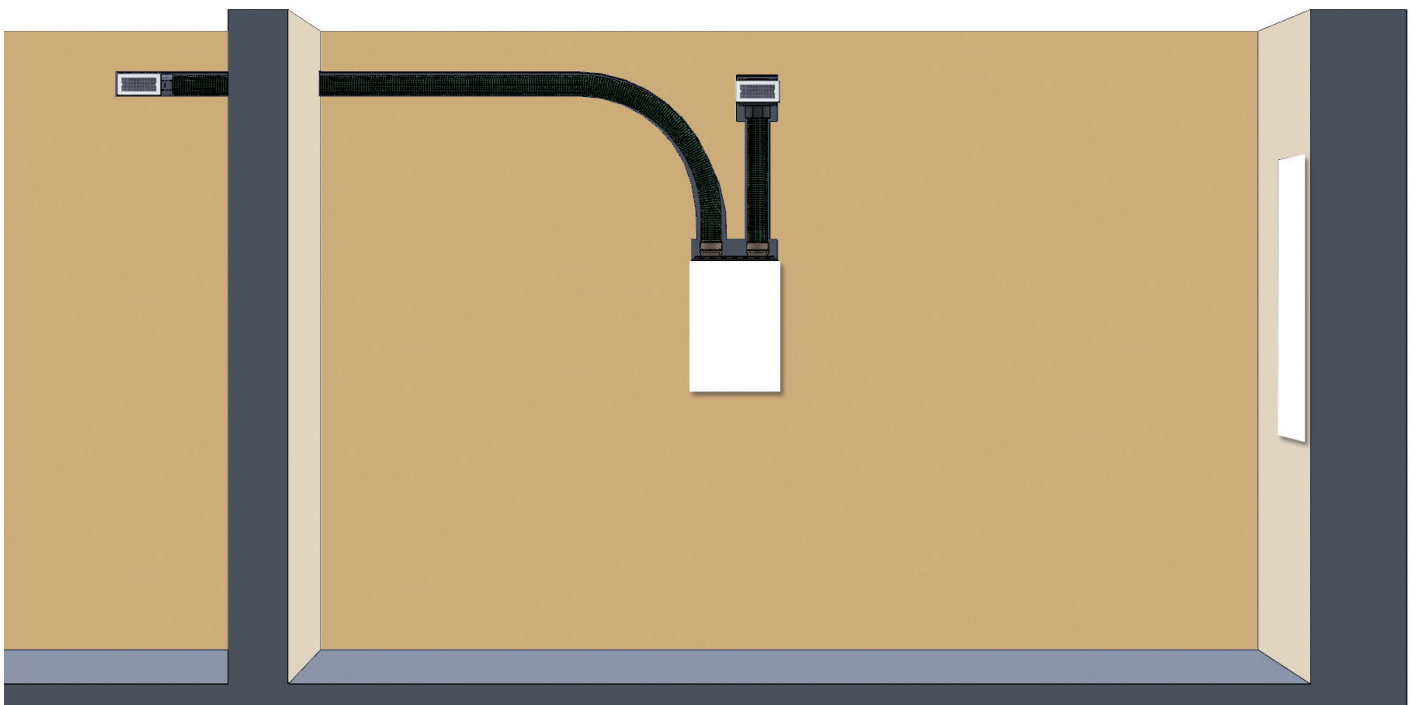
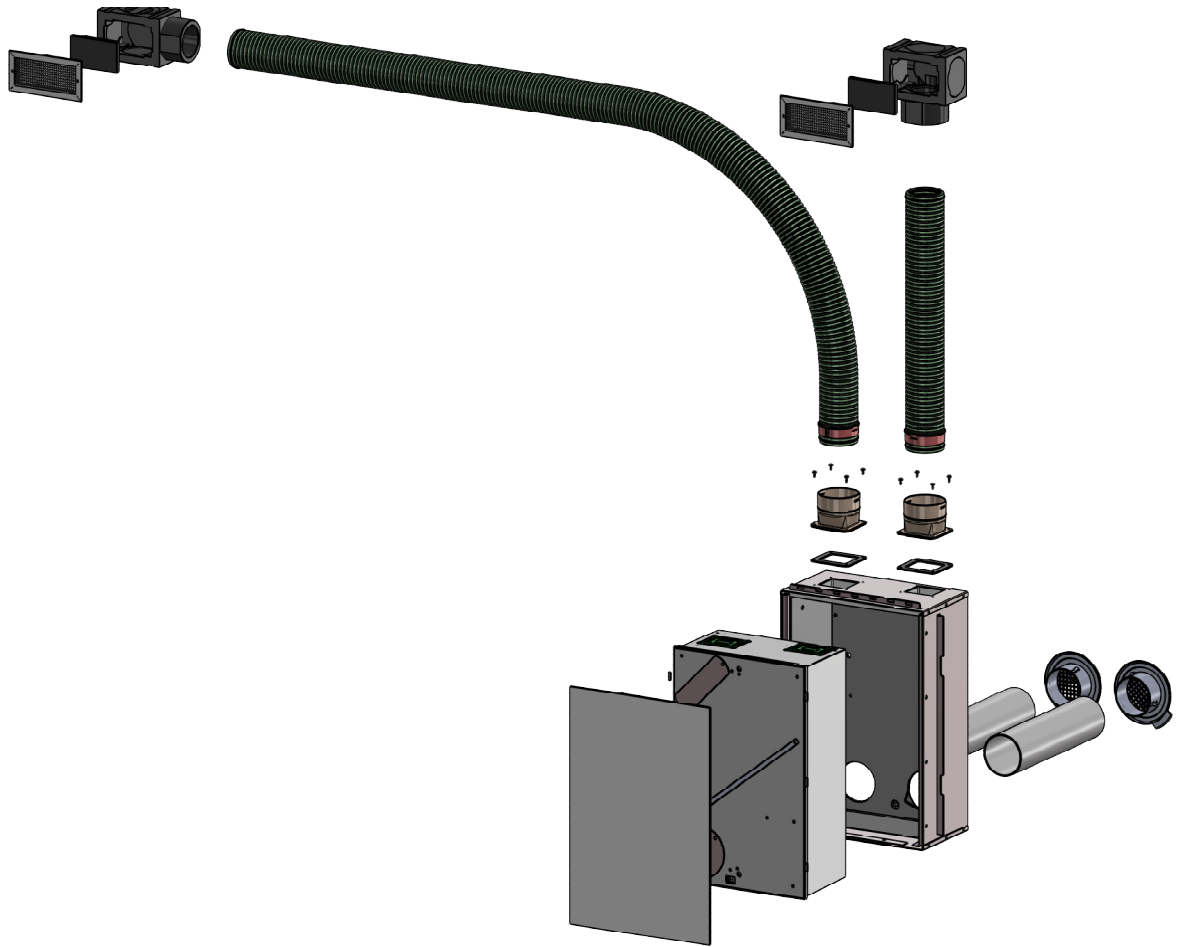

**VORT HR W-ALL 100 DF**  
DUAL-FLOW HEAT RECOVERY UNITS

**Accessories**

MODELS	DESCRIPTION	CODE
	<b>CB LCD R</b> Remote control unit with wired LCD panel, for recessed installation in standard UNI 503 box	21194
	<b>CB LCD W</b> Remote control unit with wired LCD panel, for wall installation	21195
	<b>CB LCD D</b> Remote control unit with wired LCD panel, for recessed installation in standard DIN box	21381
	<b>CB LCD R</b> Flush mounted box for housing the control unit in standard UNI 503 box	22461
	<b>CB LCD W</b> Wall box for housing the control unit	22732
	<b>WA SR/R</b> Kit for suction and discharge at the window reveal; ideal for installations in historic buildings with constraints on facade aesthetics.	20992
	<b>BRA.VO S1</b> Wireless remote sensor for monitoring temperature, relative humidity and VOC concentration in the target room	13147
	<b>BRA.VO S2</b> Wireless remote sensor for monitoring temperature, relative humidity and VOC, PM2.5 and PM10 concentration in the target room	13148
	<b>BRA.VO S3</b> Wireless remote sensor for monitoring temperature, relative humidity and VOC and CO <sup>2</sup> concentration in the target room	13149
	<b>BRA.VO S4</b> Wireless remote sensor for monitoring temperature, relative humidity and VOC and CO <sup>2</sup> , PM2.5 and PM10 concentration in the target room	13150

---

---

---

---

---

---

---

---

---

---

---

---

---

---

---

---

---

---

---

---

---

---

---

---

---

---

---

---

---

---

**VORT HR W-ALL 100 DF**  
DUAL-FLOW HEAT RECOVERY UNITS

The images below are taken from the CFD (Computational Fluid Dynamics) program, the same technology used in the design of Formula 1 cars, used in the development of the VORT HR W-ALL 100 DF series to optimise performance, consumption and noise emissions.

**CROSS SECTION WITH VELOCITY VECTORS**

The image represents the diffusion and propagation of fresh air in the part of the room where the product is installed, highlighting the effective air exchange.

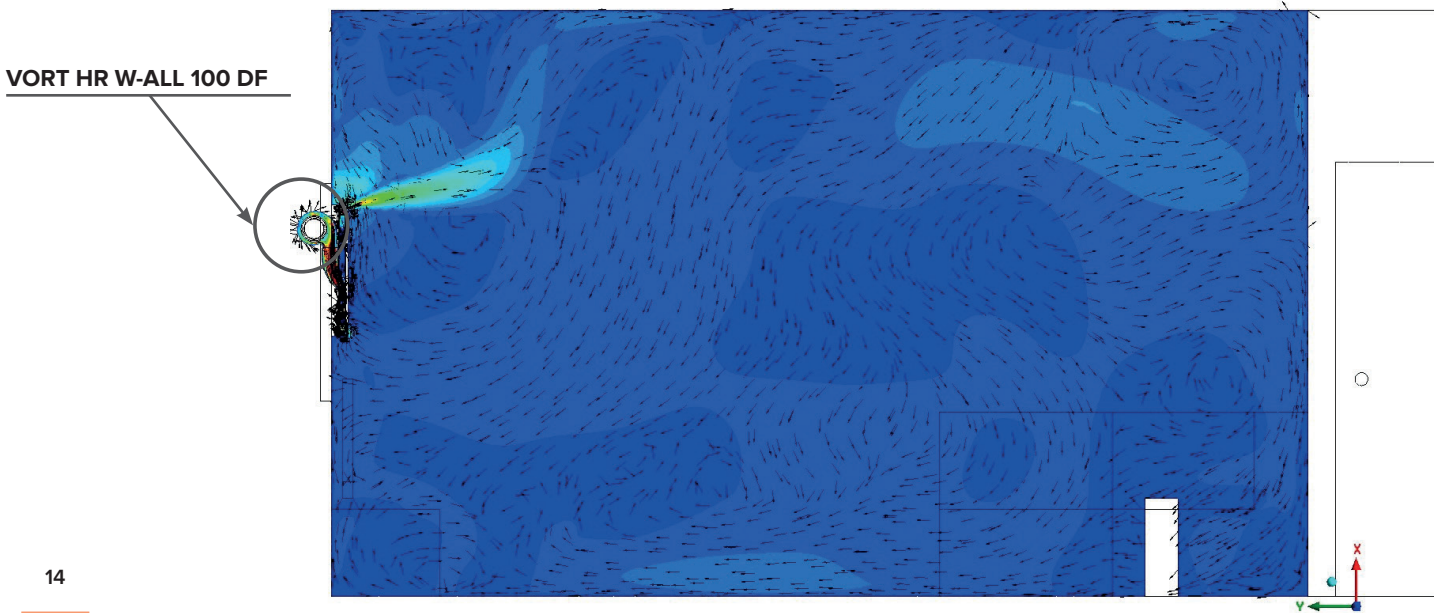

14

**ISO SURFACE**

The image represents the correct diffusion and effective propagation of fresh air in the room served by VORT HR W-ALL 100 DF, such as to ensure the correct air exchange, essential for the well-being and health of the occupants.

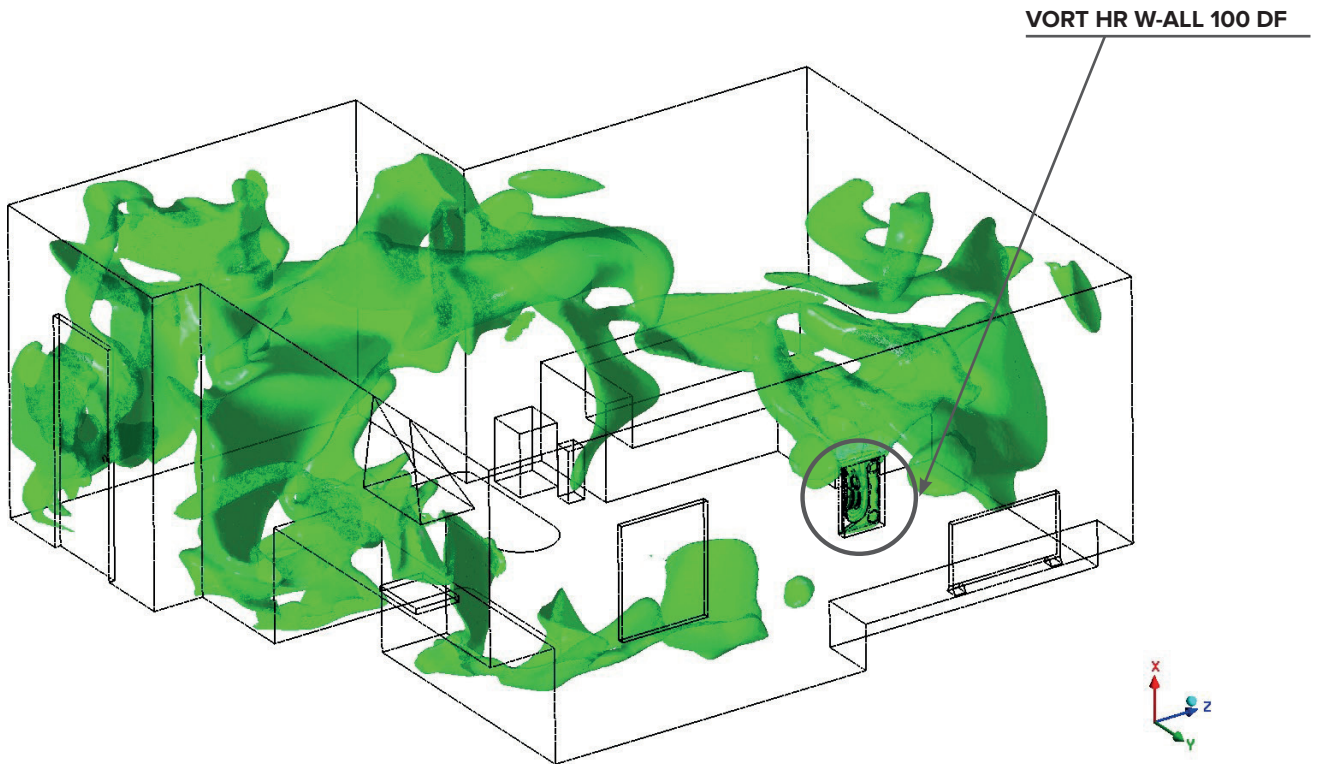

### STREAM LINE

The image describes the trajectories of the air flows induced by the product, highlighting the absence of parts of the room not affected by air exchange.

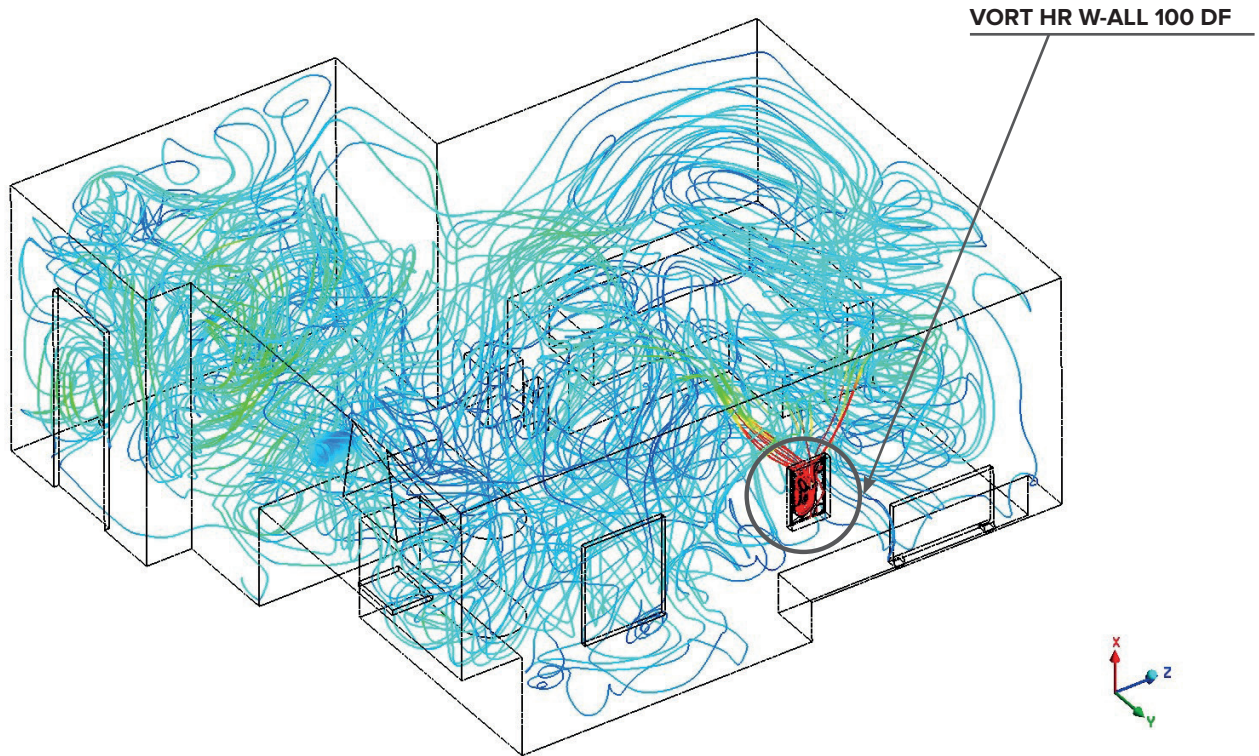

### VOLUME RENDERING

The image represents the distribution of air speed inside the room, highlighting the absence of too fast—therefore annoying—flows.

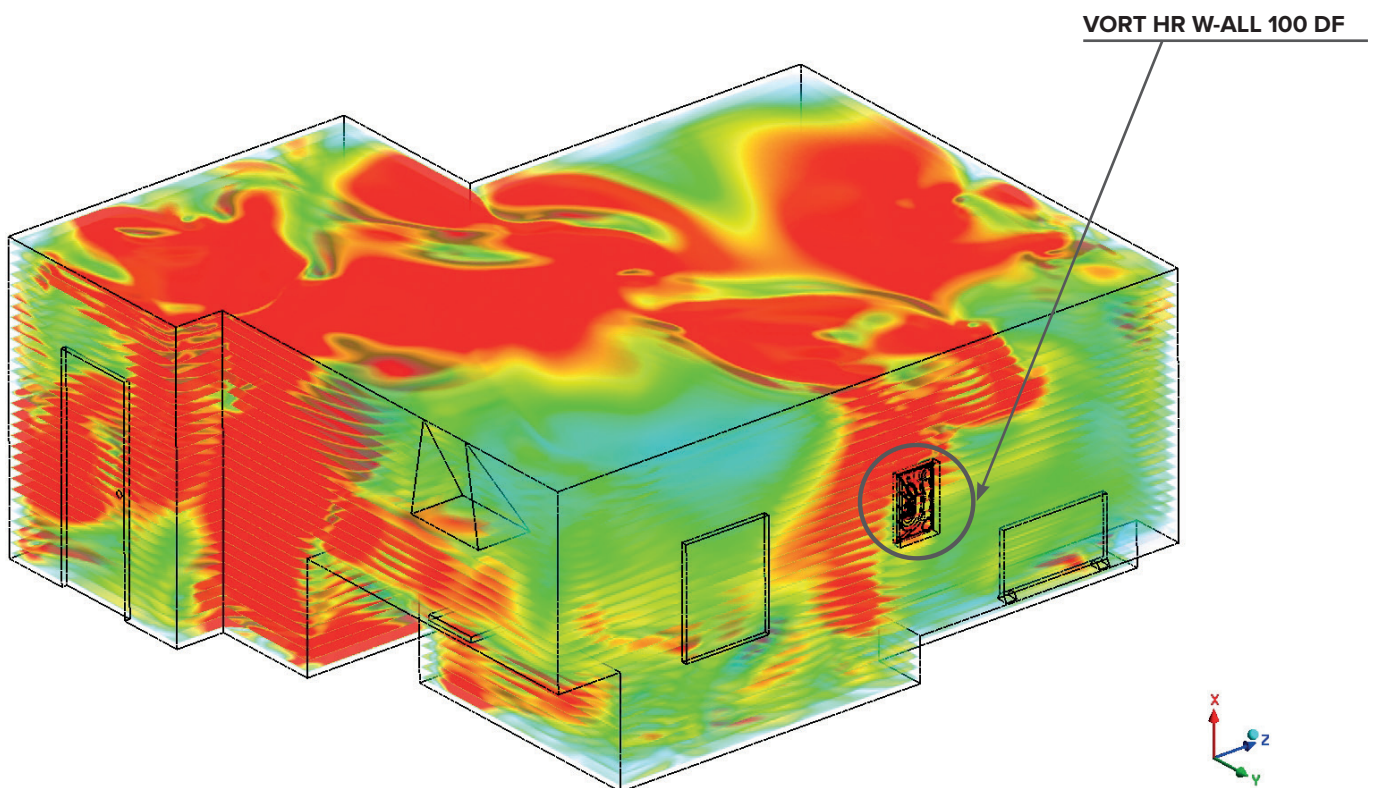

# VORTICE GROUP COMPANIES

## VORTICE S.P.A

Strada Cerca, 2  
District of Zoate  
20067 Tribiano  
(Milan) Italy  
Tel. (+39) 02 906991  
vortice.com  
V.A.T. IT 04474410968

## BUSINESS UNIT INDUSTRIAL

Via B. Brugnoli 3,  
37063 Isola della Scala  
(Verona) Italy  
Tel. (+39) 045 6631042  
vorticeindustrial.com  
V.A.T. IT 04474410968

## VORTICE LIMITED

Beeches House  
Eastern Avenue  
Burton on Trent  
DE13 0BB United Kingdom  
Tel. (+44) 1283-49.29.49  
vortice.ltd.uk

## CASALS VENTILACIÓN AIR INDUSTRIAL S.L.

Ctra. Camprodon, s/n 17860  
Sant Joan de les Abadesses  
(Girona) Spain  
Tel. (+34) 972720150  
casals.com

## VORTICE LATAM S.A.

Bodega #6  
Zona Franca Bes Alajuela,  
Alajuela 20101  
Costa Rica  
Tel. (+506) 2201.6934  
vortice-latam.com

## VORTICE VENTILATION SYSTEM

(Changzhou) Co.LTD  
No. 388 West Huanghe Road  
Building 19, Changzhou  
Post Code: 213000 China  
Tel. (+86) 0519 88990150  
vortice-china.com

The descriptions and illustrations in this catalogue are intended to be indicative and not binding. Without prejudice to the essential characteristics of the products described and illustrated here, VORTICE reserves the right to make, at any time and without notice, any changes to parts, aesthetic details or supply of accessories to its products that are deemed to be appropriate for improvement or for any construction or commercial requirement. This printout completely cancels and replaces all previous ones.

